

SPECIALIZED INSTALLATION HOOKUPS

Figure 26: Dual temperature water for food service application

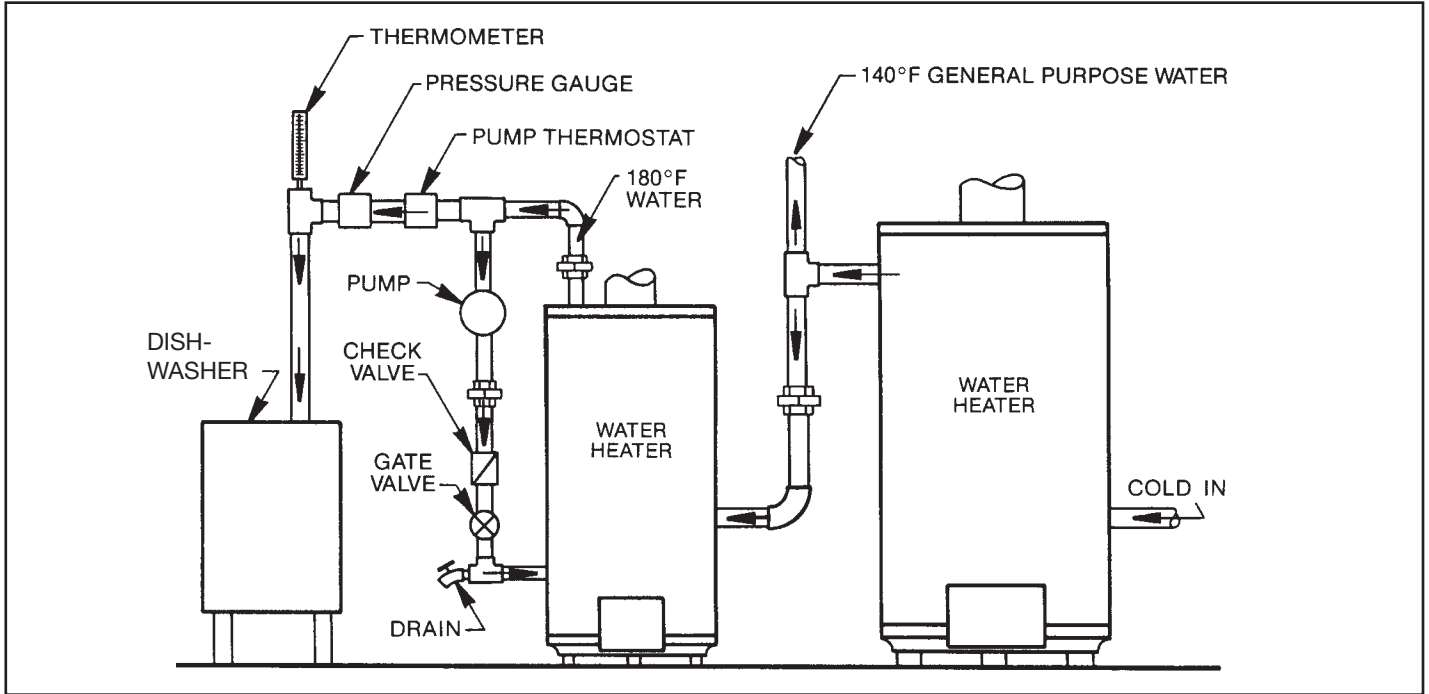
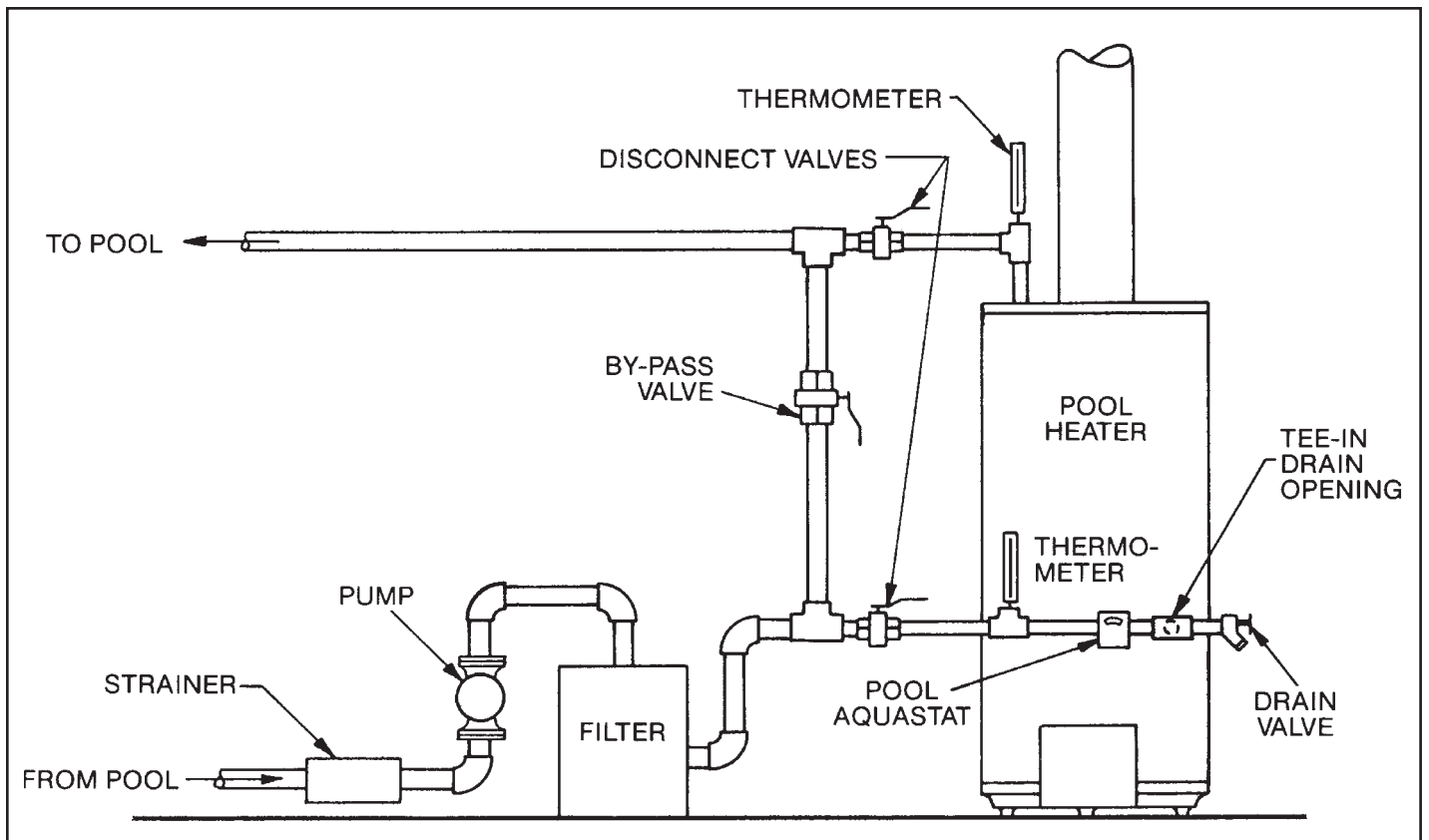

Figure 27: Swimming pool, hot tub or baptistry hookup



INDIRECT WATER HEATER INSTALLATION

Figure 28: 30SK, 40SK & 50SK installed with boiler

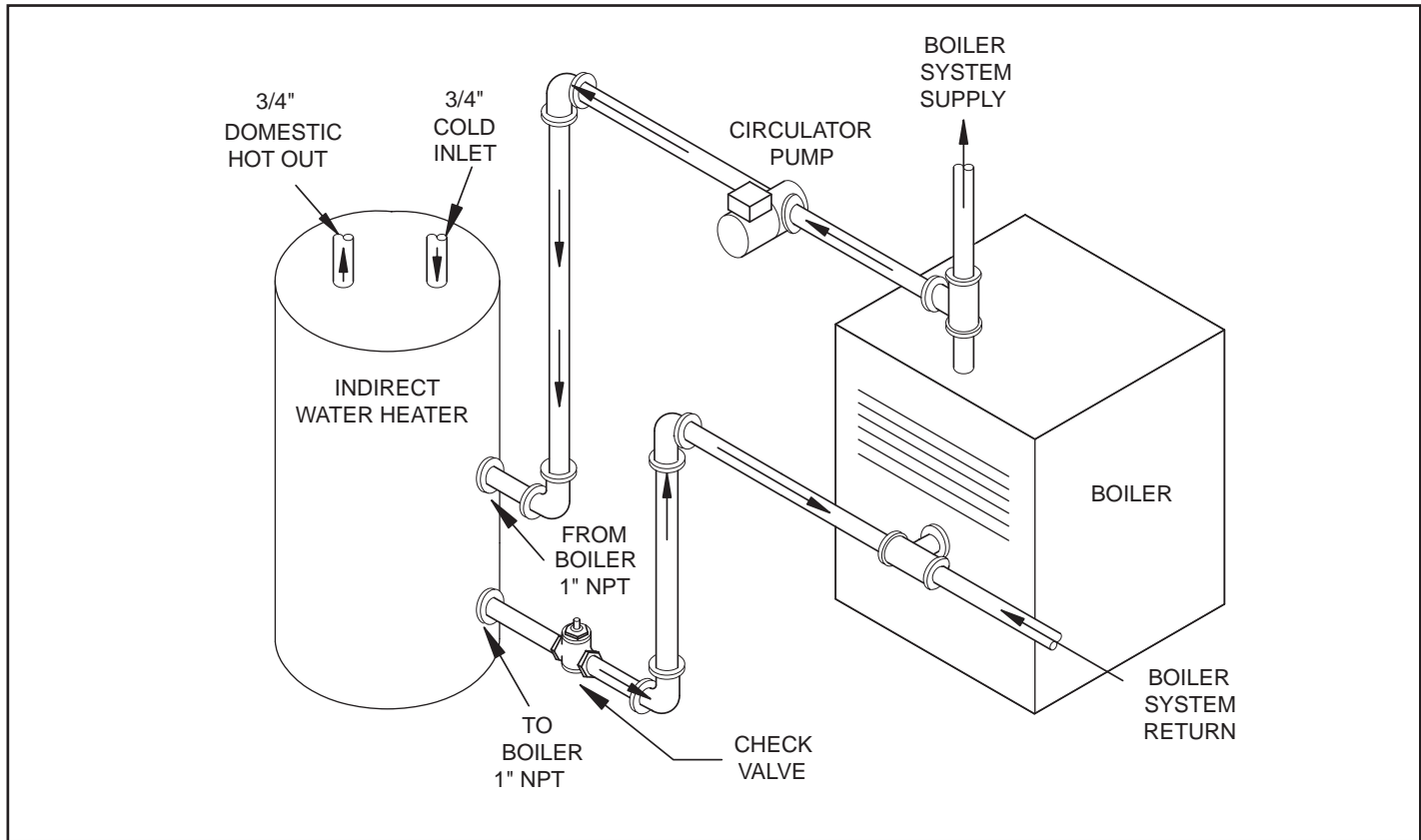
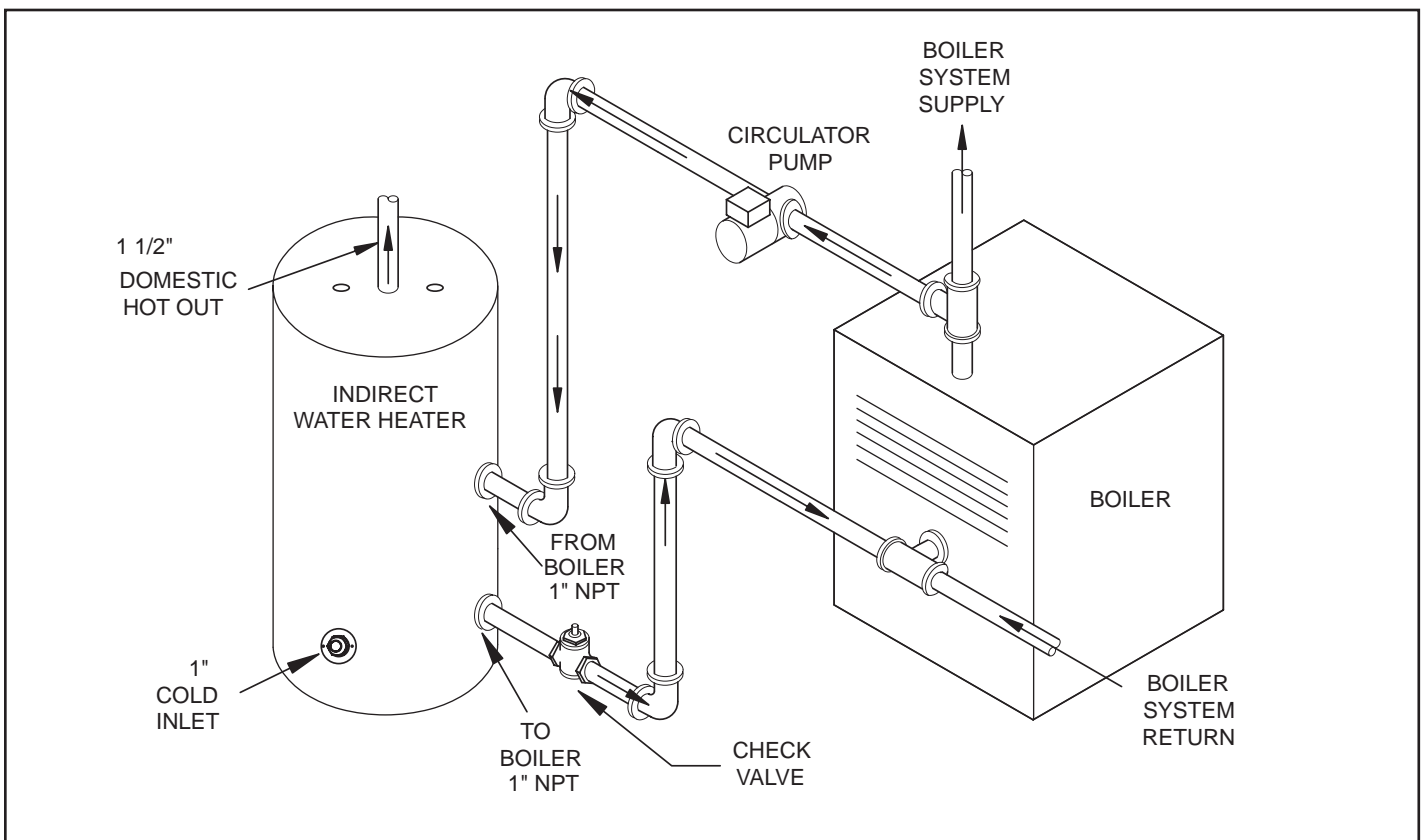

Figure 29: 80SK & 119SK installed with boiler



INDIRECT WATER HEATER INSTALLATION

See Figure 30 for piping your Bock Indirect Coil Tank Water Heater to a low-mass boiler (diagram recommended by boiler manufacturer).

Figure 30: Bock Indirect with Low-Mass Boiler

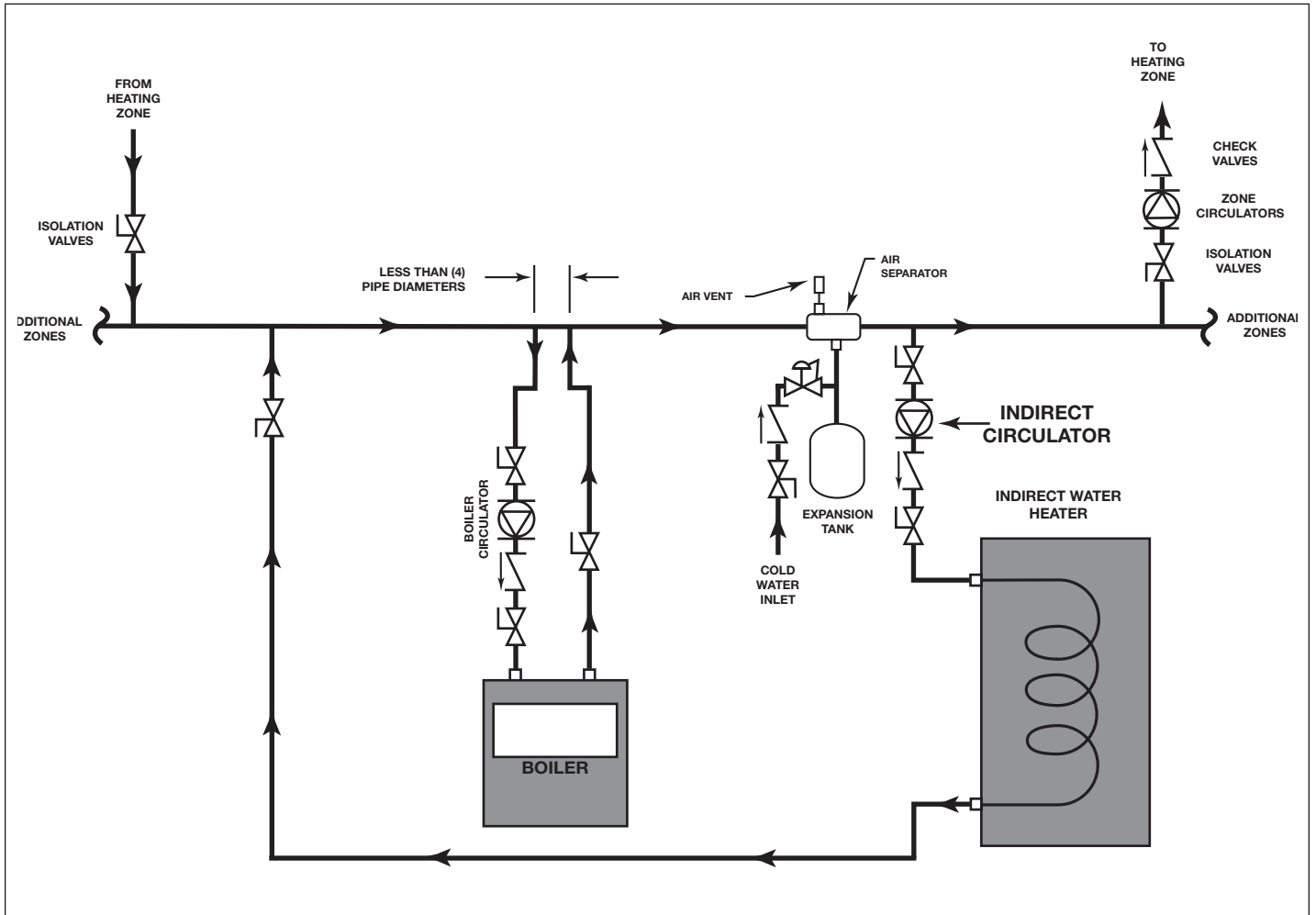

SYSTEM PLUS INSTALLATION FOR HYDRONIC HEATING

Figure 31

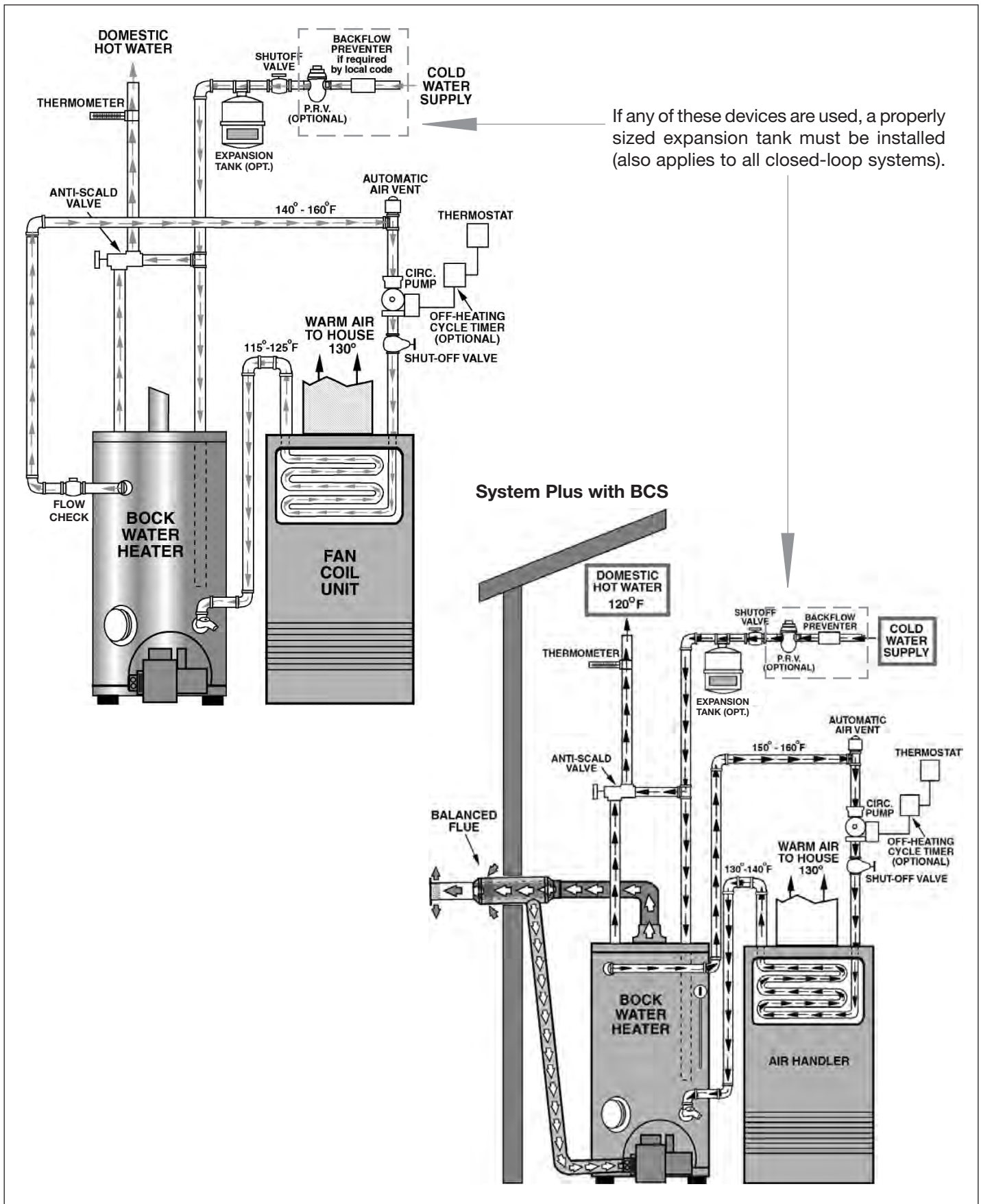

RADIANT HEATING

Where permitted by code jurisdictions, a domestic water heater may be used as a heat source for hydronic radiant heating in a closed system, provided all generally accepted plumbing practices for closed-loop hydronic heating are used.

Sizing: The water heater net output should be within the range of 100% to 120% of the calculated heat loss unless design factors, piping losses or water heater ratings require that the selection exceed this range.

Additional output capacity should be allowed when other heating demands such as domestic water, priority systems, hot tubs, swimming pools, snow-melting equipment, etc. are serviced from the water heater.

Note: Proper sizing of the water heater can be obtained from the radiant equipment manufacturer using their design criteria.

- ✓ Bock water heaters operate at lower temperatures than boilers, using less fuel to heat potable and radiant water
- ✓ Bock water heaters' high BTU output makes them far more efficient for radiant heating than boilers
- ✓ One unit heats both water and the home for greater economy
- ✓ A well-designed hydronic radiant system can reduce fuel use by as much as 40%
- ✓ Hydronic radiant supply heat is between 90°F to 140°F; conventional heat supply heat is between 160°F to 200°F
- ✓ Hydronic radiant heat works with conventional heating systems and is ideal for hard-to-heat areas
- ✓ Hydronic radiant heat can be used in new construction and retrofitting or remodeling.
- ✓ Hydronic radiant heat uses hot water to warm the home, avoiding the dry "scorched" air produced by conventional heating systems.

Figure 32: Water heater installation for radiant and domestic water heating

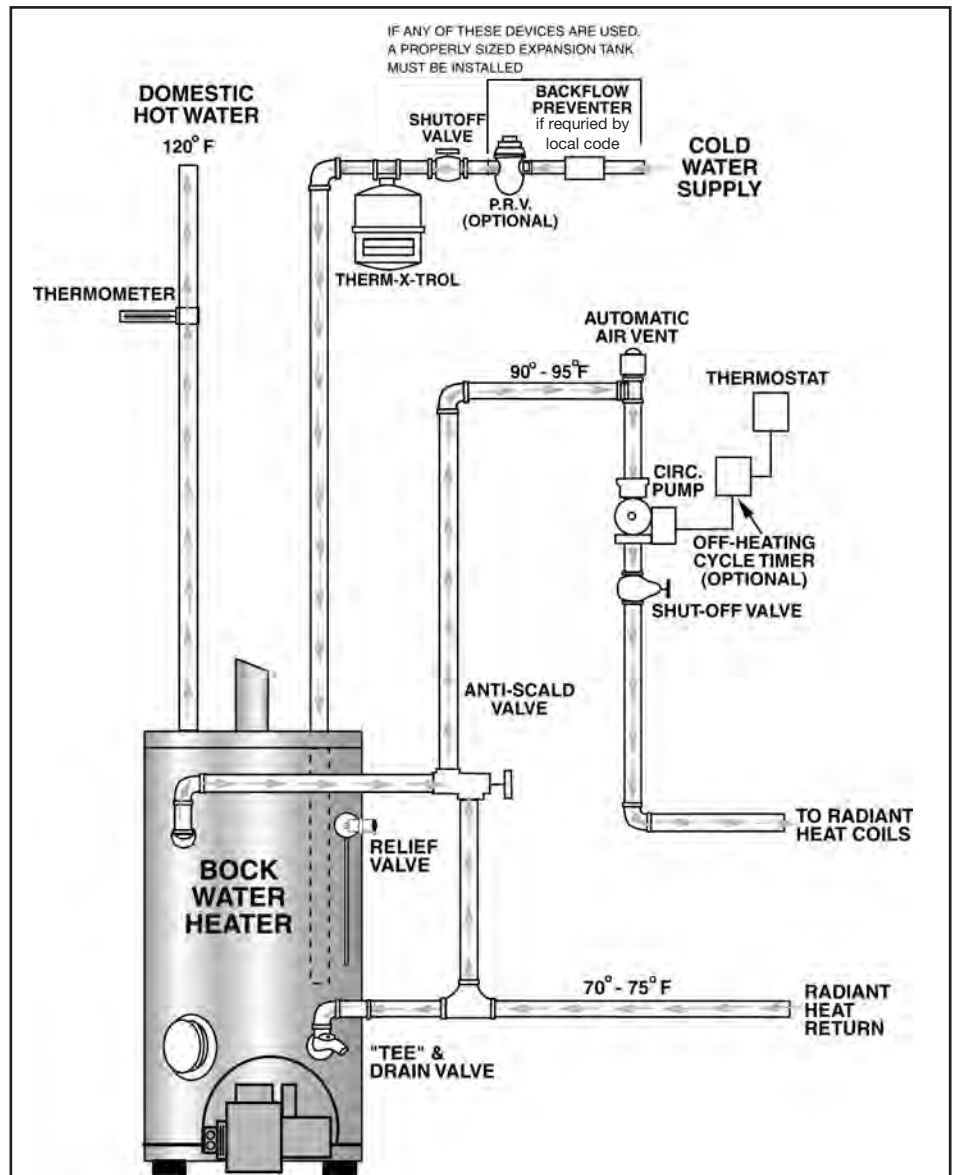

COMBINED APPLIANCE SIZING

Water Heater Sizing

Three factors must be considered:

1. Heat loss of structure
2. Hot water consumption
3. Required storage (hot tubs, whirlpools, multiple or larger shower heads)

Method 1:

Calculate heat loss of the structure and add 10% for an average family of four to obtain the minimum output of the required water heater.

75,000 BTU (heat loss) + 7,500 BTU (10% allowance for a family of four) = 82,500 BTU (required minimum output)

With this information, the required input can be calculated as follows:

Output - recovery efficiency ** = minimum input required

Example: 82,500 (BTU output) divided by 80% (.80) = 103,125 (minimum BTU input)

** recovery efficiency per GAMA directory

Method 2

Multiply the heat loss of the structure by a factor of 1.51* to obtain the input requirements of the water heater. (In northern tier states, a factor of 1.58 is suggested.)

75,000 BTU (heat loss) X 1.51 = 113,250 minimum BTU input

* This is a quick estimate calculation and should only be used to estimate heater sizing.

Air Handler / Coil Unit Sizing

Determine the heat loss of the area to be heated. Select an air handler / coil unit with a heating output that exceeds the space heat loss. The heating output of the air handler / coil (BTUH) must not exceed the output (BTUH) of the water heater. Consult with the air handler / coil manufacturer for specifications.

MULTIPLE HOOKUPS

There are four types of hookups, each with their own advantages and disadvantages.

The Parallel System

The parallel system permits water heaters to be operated at the same temperature if they are perfectly balanced in the piping. Perfect balance is easy to accomplish with a new installation but almost impossible when either heater is replaced or the piping is altered. Any piping imbalance results in one heater working more than the other and reduces recovery and usable storage. The parallel system allows for isolating either water heater at any time and is recommended when high volume peak loads occur in short periods of time and the gallons-per-hour flow is a prime factor in sizing.

The Series System

The series system solves the imbalance problem by forcing all the water through both heaters to maintain full recovery rates. The first heater is usually set at a lower temperature (i.e. 120°F) than the second heater (i.e. 140°F). While the first heater must raise the water temperature by about 65 degrees and the second by only 20 degrees, they work equally hard because maintaining the higher water temperature of the second heater is as hard on a water heater as the longer firing time of the first heater. The series system also has the advantage of being a simpler, less costly installation, a better hookup for drawing off hot water in the tanks

and a means of prolonging the life of the heaters. However, pressure drop through the system is greater and less flow per minute is available.

The Isolating Series

The isolating series is a variation of the series system resulting in full recovery rates, equal life expectancy and easy isolation of either unit. This system provides a backup in case of heater failure, can be a cost savings versus one large unit and can provide dual temperature water without mixing valves.

The Reverse Storage Tank System

The reverse storage tank system draws hot water off the heater and uses the storage tank as backup. It is ideal for applications such as schools or country clubs having high water demands for nine months of the year and minimal requirements for the remaining three months. When the extra capacity is not required, the circulating pump can be turned off. This system allows a smaller water heater to maintain high peak loads by running off-peak to maintain extremely large reserves for peak periods. This system will maintain uniform temperatures for long periods of time, until both the heater and storage tank have exhausted their storage capacity. If necessary, the tank can be maintained with its own thermostat at a lower temperature than the water heater. This is also a good application for two-temperature water without a mixing valve.

Figure 33: Three water heaters in series

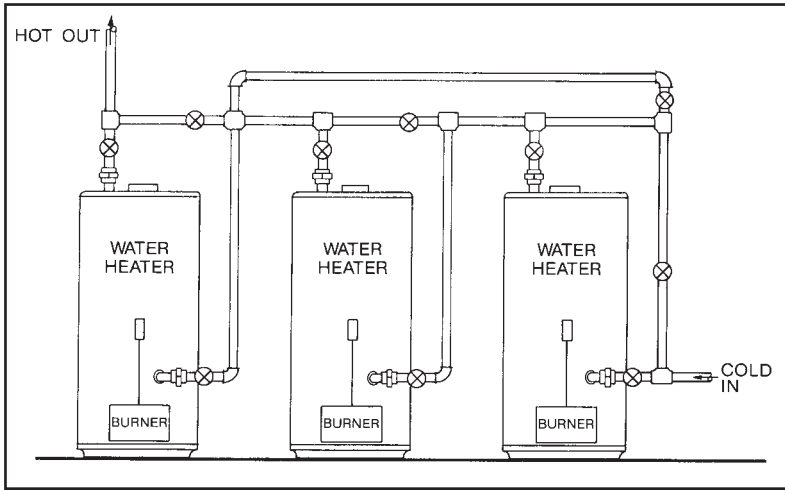

**Figure 34:
Series hookup
with bypass**

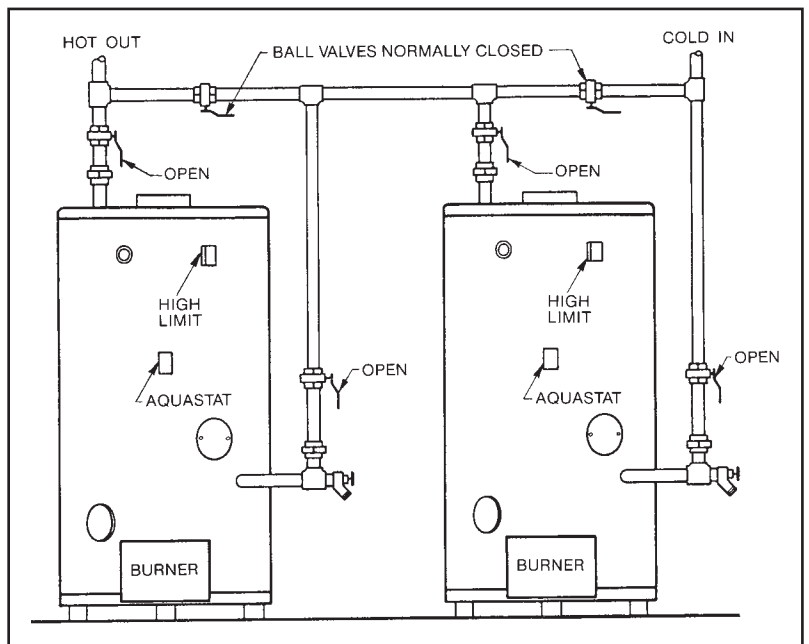

Figures 35 and 36: Two water heaters with mixing valve

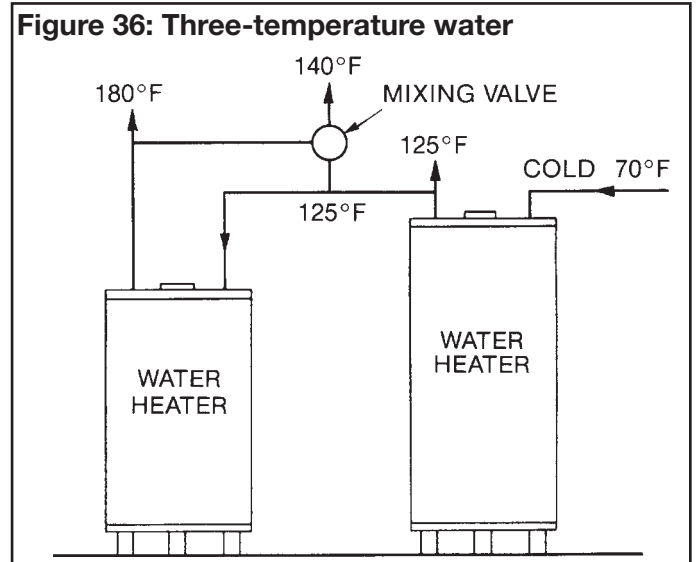
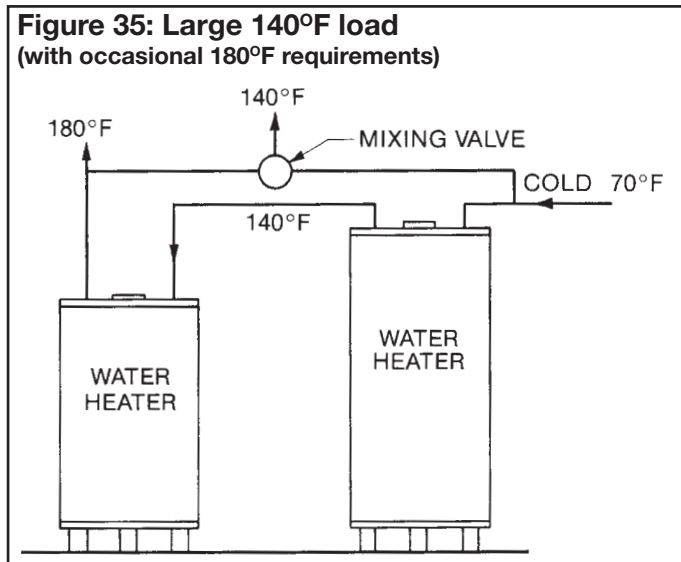
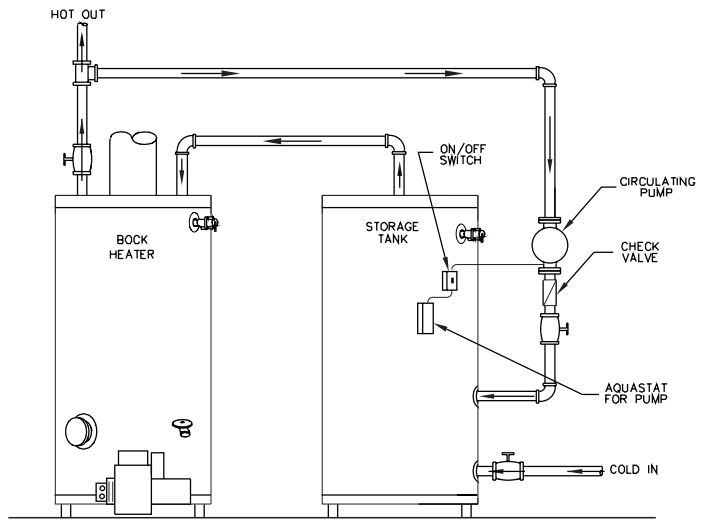

Figure 37: REVERSE STORAGE TANK SYSTEM HOOKUPS

Using a reverse storage tank system hookup can reduce energy consumption when compared to a conventional hookup if the pump is turned off whenever the extra storage capacity is not needed. Such applications are recommended for use in schools using hot water only nine months each year, churches that use large amounts of hot water primarily on weekends, milk houses, dorms, weekend residential housing and homes with large whirlpools or hot tubs. The reverse storage tank system reduces standby losses and allows a small heater to provide as much hot water as a larger unit.



WATER HEATER WITH STORAGE TANK

Figure 38

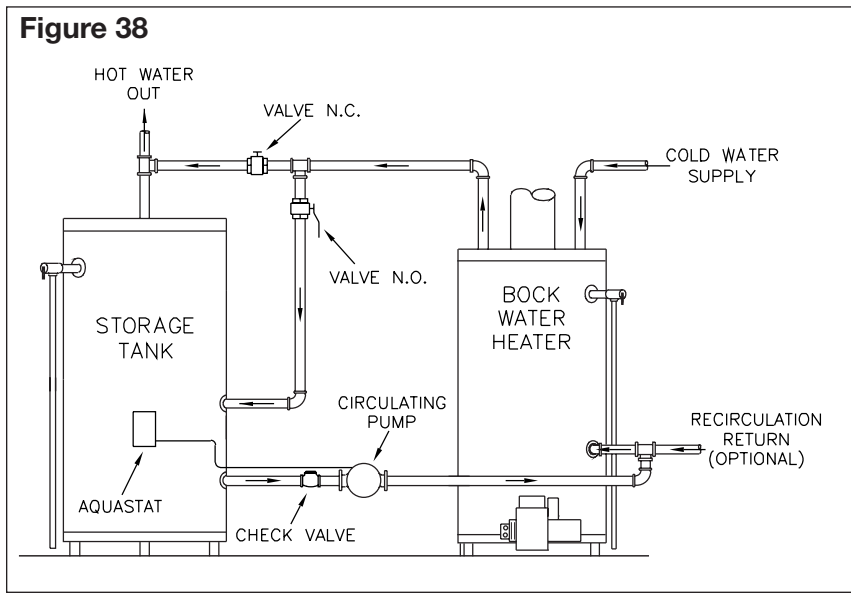
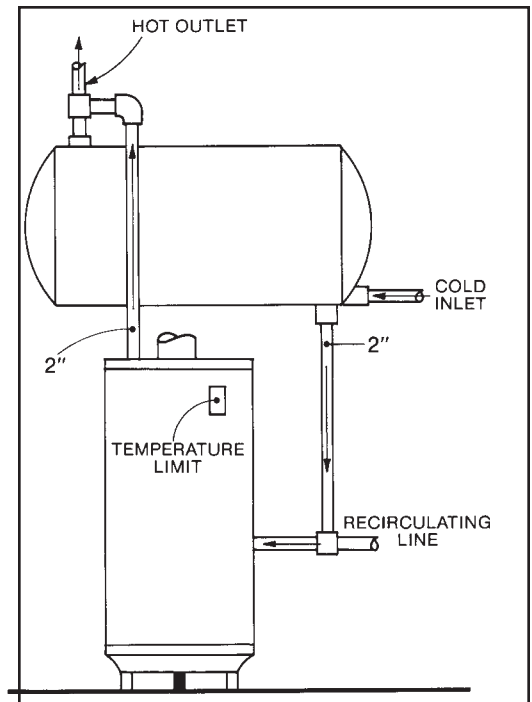
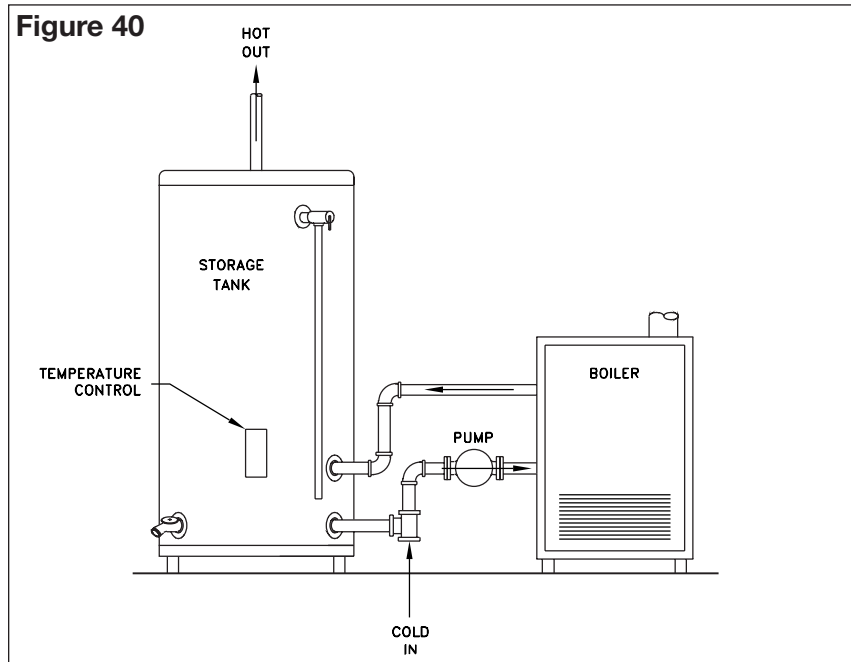

Figure 39: Single heater and large storage tank, gravity flow



STORAGE TANK AND BOILER INSTALLATION

Figure 40



TWO HEATERS AND STORAGE TANK – PARALLEL PIPING

Figure 41

NOTE – SET HEATER THERMOSTATS 5° HIGHER THAN STORAGE TANK THERMOSTAT

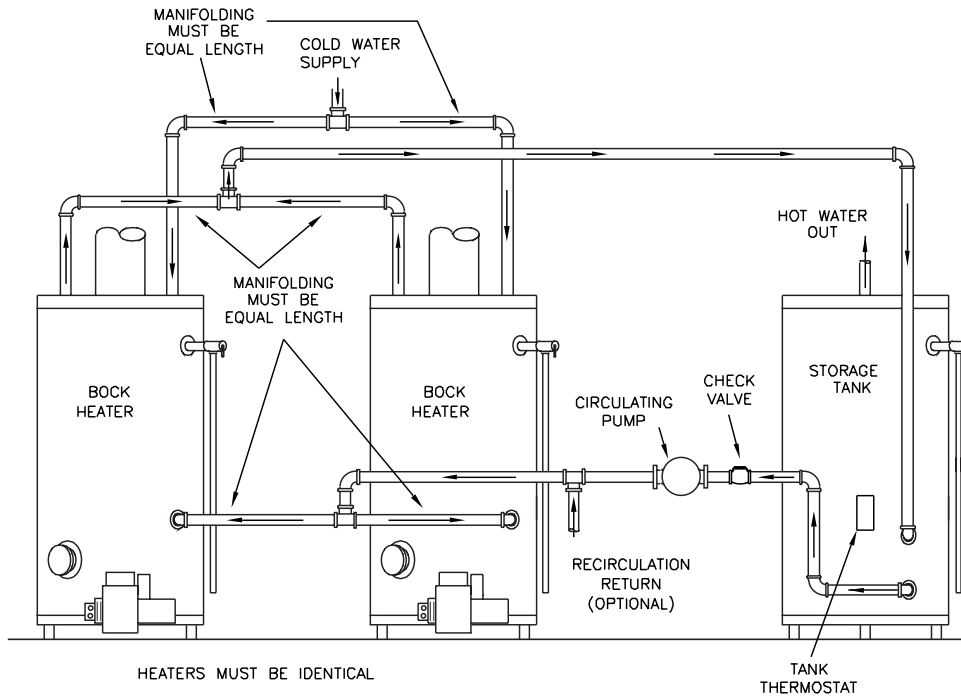

TWO INDIRECT WATER HEATERS WITH HEAT SOURCE

Figure 42

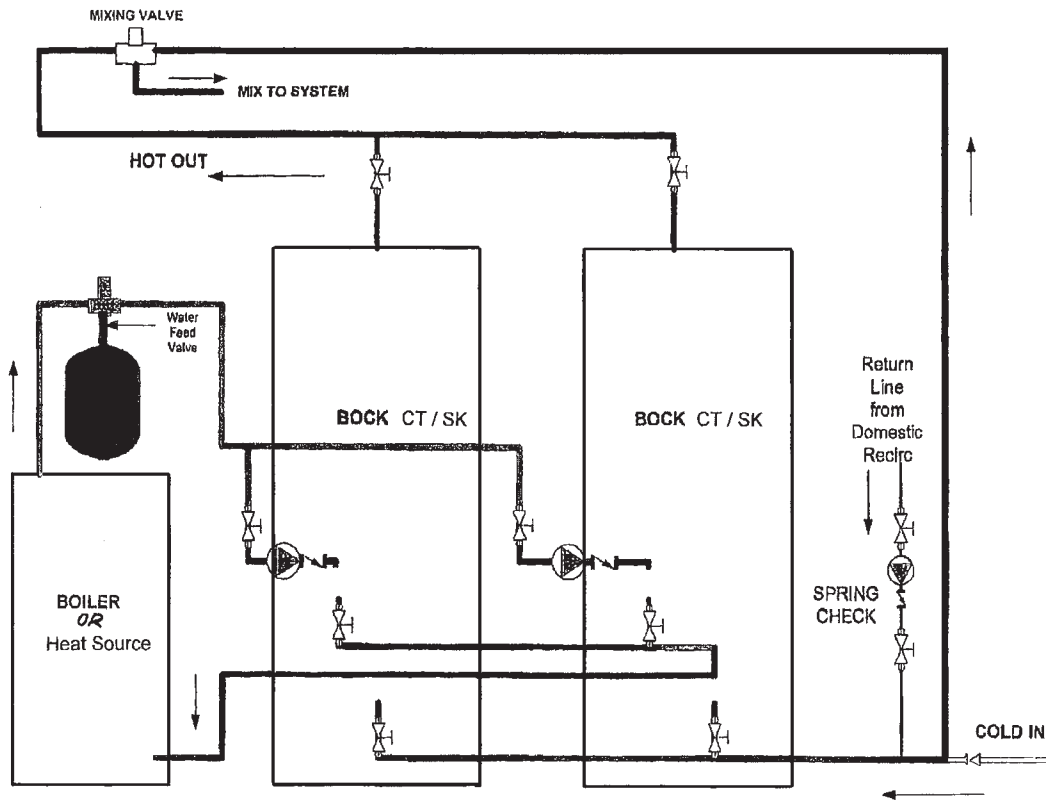

Typical Reverse System / Sample Drawing - Not to Scale
 **Anti-scald / tempering valve and domestic recirc must be used.

WEIGHTS, MEASURES, METRIC CONVERSIONS – Table 20

METRIC SYSTEM		U.S. SYSTEM	
LINEAR MEASURE		LINEAR MEASURE	
10 Millimeters	= 1 Centimeter	12 inches	= 1 foot
10 Centimeters	= 1 Decimeter	3 feet	= 1 yard
10 Decimeters	= 1 Meter	5 1/2 yards	= 1 rod
10 Meters	= 1 Dekameter	40 rods	= 1 furlong
10 Dekameters	= 1 Hectometer	8 furlongs (5,280 feet)	= 1 mile
10 Hectometers	= 1 Kilometer	3 land miles	= 1 league
		6,086 feet	= 1 intl. nautical mile
AREA MEASURE		AREA MEASURE	
100 sq. Millimeters	= 1 sq. Centimeter	144 sq. inches	= 1 sq. foot
10,000 sq. Centimeters	= 1 sq. Meter	9 sq. feet	= 1 sq. yard
1,000,000 sq. Millimeters	= 1 sq. Meter	30 1/4 sq. yards	= 1 sq. rod
100 sq. Meters	= 1 Are (a)	160 sq. rods	= 1 acre
100 Ares	= 1 Hectare (ha)	640 acres	= 1 sq. mile
100 Hectares	= 1 sq. Kilometer	1 sq. mile	= 1 section
1,000,000 sq. Meters	= 1 sq. Kilometer	36 sections	= 1 township
VOLUME MEASURE		LIQUID MEASURE	
1 liter	= 0.001 cubic meter	4 gills (2 cups)	= 1 pint
10 millimeters	= 1 centiliter	2 pints	= 1 quart
10 centiliters	= 1 deciliter	4 quarts	= 1 gallon
10 deciliters	= 1 liter		
10 liters	= 1 dekaliter	DRY MEASURE	
10 dekaliters	= 1 hectoliter	2 pints	= 1 quart
10 hectoliters	= 1 kiloliter	8 quarts	= 1 peck
		4 pecks	= 1 bushel
WEIGHT		WEIGHT	
10 milligrams	= 1 centigram	27 11/32 grams	= 1 dram
10 centigrams	= 1 decigram	16 drams	= 1 ounce
10 decigrams	= 1 gram	16 ounces	= 1 pound
10 grams	= 1 dekagram	100 pounds	= 1 hundredweight
10 dekagrams	= 1 hectogram	20 hundredweight	= 1 ton
10 hectograms	= 1 kilogram		
1,000 kilograms	= 1 metric ton		

GENERAL WEATHER GUIDELINES IN CELCIUS & FAHRENHEIT

0°CFreezing point of water (32°F)	40°CHeat wave conditions (104°F)
10°CWarm winter day (50°F)	100°CBoiling point of water (212°F)
20°CMild spring day (68°F)	°C = (°F - 32) * 5/9
30°CWarm day (86°F)	°F = (°C * 9/5) + 32
37°CNormal body temperature (98.6°F)	

MEASUREMENT CONVERSIONS

FROM	MULTIPLY BY	.TO FIND	FROM	MULTIPLY BY	.TO FIND	FROM	MULTIPLY BY	.TO FIND
Centimeters	.394Inches	Kilograms	1,000.0Grams	Miles	5,280.0 Feet
	.0328 Feet		35.274 Ounces		1,770.0 Yards
Feet	30.48Centimeters		2.205 Pounds		1,609.0 Kilometers
	.3048 Meters	Kilometers	3281 Feet	Ounces	28.35Grams
	.0001894Miles		1,000.0 Meters		.0625 Pounds
	.3333 Yards		.621 Miles		.028 Kilograms
Gallons	8.0 Pints		1093.0 Yards	Pints	.473 Liters
	3.785 Liters	Liters	2.113 Pints		.50 Quarts
	4.0 Quarts		.264 Gallons		.0125 Gallons
Grams	.035 Ounces		1,000.0 Milliliters	Pounds	453.59Grams
	.002 Pounds	Meters	3.281 Feet		16.0 Ounces
	.001 Kilograms		39.37Inches		.454 Kilograms
Inches	2.54Centimeters		.001 Kilometers	Quarts	2.0 Pints
	.0833 Feet		.0006214Miles		.946 Liters
	.0254 Meters		1.093 Yards		.25 Gallons
	.0278 Yards				Yards	.914 Meters
							.0005682Miles